

KOBELCO[®]

SK210LC ACERA MARK 8



Operating Weight
47,800 lbs

NET Horsepower
150 @ 2,000 rpm

Max Digging Depth
22'0"

Bucket Capacity
.63 to 1.80 cu yd

Bucket Breakout Force (SAE)
31,700 lbs



Easy, ground-level servicing of filters, batteries and hydraulics reduces maintenance time to boost your productivity.



ACERA Mark 8™



A NEW LEVEL OF PRODUCTIVITY AND CONTROL

Kobelco continues to set the standard for jobsite performance and operator control. The new SK210LC Acera Mark 8 hydraulic excavator uses technology borrowed from the SK350LC to deliver unsurpassed digging performance with unmatched precision control. That makes it perfect for applications that require maximum power for digging and fine control for grading and leveling.

A Cab Designed Around You, the Operator

- Oversized cab provides ample room and numerous comfort features
- Operator visibility is excellent in all directions, with minimal obstructions
- New control locations provide easy access to critical functions
- Climate-controlled A/C & heating system is perfect for all climates

Powerful Productivity

Kobelco's industry-leading performance numbers just got even better

- Increased horsepower and efficiency delivers pure performance
- 10% more Swing Torque for moving fully loaded buckets
- Independent Travel provides more control when carrying a load and traveling
- An astounding 6,800 lb. increase in Drawbar Pull force gives you the confidence to climb a grade while carrying a heavy load
- Arm Digging force has also been increased by 6% for more strength coming out of the hole or trench

Proven System Power

- Reliable 409 cu. in. (6.7 L), 6-cylinder water-cooled, turbocharged engine
- 150 (SAE) Net engine horsepower (112 kW) @ 2,000 rpm
- 10% more power with “no time limit” from our Power Boost™ system
- 10% more power with “no time limit” from our Heavy Lift system
- Top Notch warranty and support from our Kobelco dealer network

Kobelco builds high performance excavators that are the envy of our competitors. When you buy or rent a new Kobelco SK210LC Acera Mark 8 excavator, you're getting power, comfort and reliability, all in a proven excavator design. See your Kobelco dealer for a demonstration or visit www.kobelcoamerica.com to find the dealer nearest you.

Spacious dimensions and an unrivaled view make the Kobelco cab a comfortable and productive place to work.

The SK210LC provides superior bucket and arm digging forces so you can easily handle the most demanding digging conditions.





Diagnostic system monitors vital functions and provides you with complete operating information.

Operators work with confidence and ease with a clear view of the jobsite.



SK210LC

SUPERIOR VISIBILITY AND CONTROL

Let's face it, you can't perform at your best if you're not comfortable. Kobelco has gone to the extremes to ensure that our customers enjoy operating our excavators. The SK210LC delivers complete operational control, maximum comfort, progressive hydraulic acceleration and a 360 degree view. The perfect combination for a very productive day.

Near-Perfect Visibility

- Large glass panels on all sides of the cab provided a near unobstructed view
- Operator is positioned for maximum visibility of all functions and operations

Comfortable Seating

- 7-position suspension seat provides adjustment for maximum comfort
- Viscous silicon cab mounts minimize vibration and shock to the cab
- Wide entry/exit area provides easy access to the roomy cab
- AM/FM stereo with dual speakers is standard
- 24 volt to 12 volt converter for charging cell phones and other accessories

Enhanced Controllability

- Intelligent Total Control System (ITCS) recognizes your moves and assists with smooth engagements and disengagements
- Auto-acceleration system smoothly increases engine rpms to full speed in proportion to the operator's movement of the control levers. This results in even, deliberate acceleration for precise operations
- Heavy Lift mode provides additional power for lifting heavy loads
- Power Boost provides increased force for heavy bucket digging
- Independent travel circuit, exclusive to North American Kobelco products, provides dedicated flow for excavator travel

Easy-to-Read Instruments

- Central gauge cluster includes work mode selector switch, fuel and temperature gauges, and an orange backlit multi-display with large sun shade
- Self-diagnostics with fault code memory makes it easy to monitor and adjust system pressures, speeds other operating functions
- Warning screens and alarms alert you to temperature and pressure status
- Establish and review service intervals for engine oil, hydraulic oil, fuel and filters





The operator seat adjusts seven ways to fit operators of any size.

A personal climate control console includes an LCD display and controls for the high-output air conditioning and heating system and the four-speed fan. Just program a temperature between 61 and 91 degrees F (18 to 32 C) for optimum comfort any time of year.



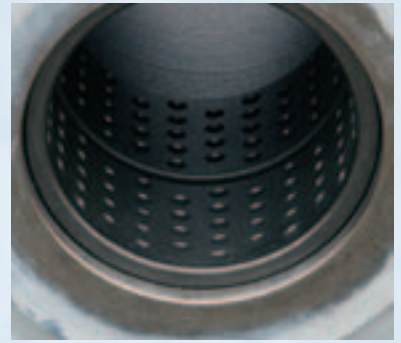

Flanged brass bucket bushings provide long life and extended maintenance intervals.

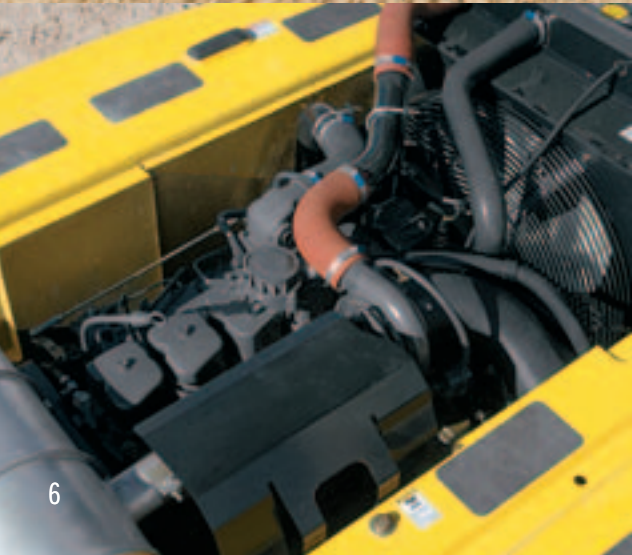

Dependable 409 cu. in. (6.7 L) 6-cylinder turbo-charged engine produces 490 ft.-lbs (666 N•m) of torque

The Power mode system provides four power modes to match your work operations. The monitor features a large sunshade and orange back-lit screen for easy viewing.



REPOWERED FOR PERFORMANCE

To meet Tier III engine requirements we've repowered the SK210LC with a proven power train technology 150 net horsepower 6-cylinder, direct injected diesel engine with intercooler turbocharger. This engine features 490 ft-lbs of torque (Net) at 1,200 rpm, a 14% increase in torque over the previous SK210.

Power Mode Selection

Provides four modes for work operation:

- **H Mode** Heavy-duty excavation work, gives priority to the workload at high speed (default mode)
- **S Mode** Standard digging and loading work, provides fuel savings
- **B Mode** Breaker work (1-way hydraulic flow)
- **A Mode** Demolition work with crusher/nibbler-breaker (2-way /1 or 2 pump flow)

Change modes easily on the readout display

Auto Warm-up System

Our auto warm-up system is designed to warm-up the hydraulic circuit to an optimum 126 degree (F). Kobelco recommends using this system whenever ambient temperatures drop below 50 degrees (F). This feature improves the efficiency of your hydraulic system so you can focus on productivity.

Auto Acceleration System

If not used for more than 4 seconds, the SK210LC engine will automatically Decelerate to 1,200 rpms or, the range or setting pre-programmed by operator. This saves costly fuel, extends service intervals and provides longer engine life. Auto Acceleration increases engine rpm proportionally and in direct response to movement of the control lever by operator. This gives YOU power ***"on command, without lag"***.

Smooth, Powerful Hydraulic Performance

Kobelco provides performance features that are unmatched by the competition.

- Power Boost™ provides 10% more bucket breakout force, ***"without time limit"***
- Heavy Lift provides 10% more lifting capability, ***"without time limit"***
- Boom and arm holding valves minimize drift for accurate positioning
- Standard high-flow valve can be switched between one-pump flow to two-pump flow from inside the cab
- Hydraulic flow has been increased by 5.6% for improved flow and performance

Designed with attachments in mind

Kobelco doesn't just design excavators, we design excavators for use with attachments.

- High-capacity hydraulics with in-cab adjustment
- Standard one- or two-way auxiliary valve
- Two auxiliary hydraulic modes for easy in-cab switching between one- and two-way flow (with auxiliary hydraulics installed)
- Optional independent flow and dedicated pump for multi-function attachments that include thumbs or twist buckets

The hydraulic feed to the main pumps is positioned to draw fluid from the side of the hydraulic tank - rather than the tank bottom like many competitors. The hydraulic system utilizes a high capacity, small particle filtration system to provide industry leading maintenance intervals.

Side-by-side radiator, oil cooler and intercooler can be accessed easily for inspection and cleaning. The side-by-side design allows the components to be removed independently. This means the radiator can be removed for service without draining the hydraulic system.

SK210LC DIMENSIONS, WEIGHTS & BUCKET SELECTION CHART

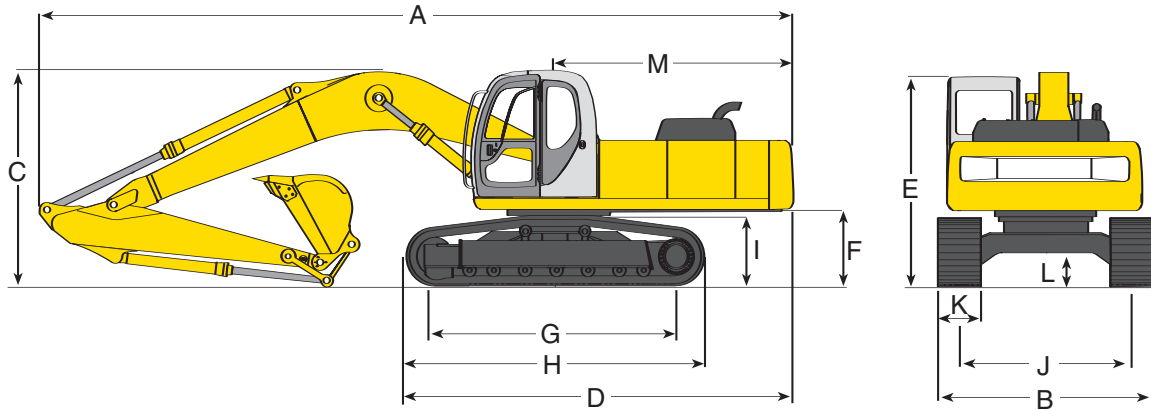

DIMENSIONS: SK210LC Unit ft-in (m)

ARM LENGTH	9' 8" (2.94)	11' 6" (3.50)
A. Overall length	31' 0" (9.45)	31' 1" (9.52)
B. Overall width (with 800mm shoe)	10' 6" (3.19)	10' 6" (3.19)
C. Overall height (to top of boom)	9' 11" (3.03)	10' 5" (3.18)
D. Basic machine length	16' 4" (4.98)	16' 4" (4.98)
E. Overall height (to top of cab)*	9' 7" (2.93)	9' 7" (2.93)
F. Ground clearance of rear end*	3' 6" (1.06)	3' 6" (1.06)
G. Center distance of tumbler	12' 0" (3.66)	12' 0" (3.66)
H. Overall length of crawler	14' 7" (4.45)	14' 7" (4.45)
I. Crawler height at tumbler center*	37' 8" (960 mm)	37' 8" (960 mm)
J. Track gauge	7' 10" (2.39)	7' 10" (2.39)
K. Width of crawler shoe	31.5" (800 mm)	31.5" (800 mm)
L. Ground clearance of undercarriage*	17.7" (450 mm)	17.7" (450 mm)
M. Tail swing radius	9' 0" (2.75)	9' 0" (2.75)

*Excludes height of grouser bar.

WEIGHTS: SK210LC with 9'8" std. HD arm, 31.5" 3-bar tracks and bucket weighing 1,430 lbs (650 kg)

SHOE WIDTH	in (mm)	35.4" (900)	31.5" (800)
Machine overall width	ft-in (mm)	10' 10" (3.290)	10' 6" (3.190)
Ground pressure	psi (kg/cm ²)	4.4 (0.309)	4.9 (0.34)
Operating weight	lb (kg)	48,300 (21,900)	47,800 (21,700)

SHOE WIDTH	in (mm)	27.6" (700)
Machine overall width	ft-in (mm)	10' 2" (3.090)
Ground pressure	psi (kg/cm ²)	5.52 (0.39)
Operating weight	lb (kg)	47,200 (21,400)

HYDRAULIC SYSTEM

Pump	2 variable displacement	
Max discharge flow	US gal/min (L/min)	2x58.1 (2x220)
Operating Pressure:		
Implement	psi (MPa)	4,970 (34.3)
Travel	psi (MPa)	4,970 (34.3)
Swing	psi (MPa)	4,210 (29.0)
Power Boost/Heavy lift	psi (MPa)	5,480 (37.8)
Pilot control circuit	psi (MPa)	725 (5.0)
Control valves	8 spool	

BUCKET SELECTION CHART

Bucket Duty	Capacity (SAE)		Width		Bucket Weight		Arm ft-in (m)	
	Cubic Yard	(m ³)	Inches	(m)	lb	(kg)	10'6" (3.2)	11'6" (3.5)
GENERAL	.91	(.695)	30"	(.762)	1,325	(601)	H	H
	1.14	(.871)	36"	(.914)	1,450	(658)	H	M
	1.37	(1.047)	42"	(1.066)	1,651	(749)	M	L
	1.6	(1.223)	48"	(1.219)	1,780	(807)	L	X
	1.8	(1.38)	54"	(1.371)	2,019	(916)	L	X
HEAVY DUTY	.68	(.519)	24"	(.609)	1,250	(567)	H	H
	.91	(.695)	30"	(.762)	1,420	(644)	H	M
	1.14	(.871)	36"	(.914)	1,560	(708)	M	L
	1.37	(1.04)	42"	(1.066)	1,730	(785)	L	X
	1.6	(1.233)	48"	(1.219)	1,905	(864)	X	X
SEVERE DUTY	.63	(.481)	26"	(.66)	1,455	(660)	H	H
	.75	(.573)	31"	(.787)	1,590	(721)	H	H
	.88	(.672)	37"	(.939)	1,790	(812)	M	M
	1.13	(.871)	43"	(1.092)	2,000	(907)	L	X

H - Used with material weight up to 3,000 lbs/cu yd (1,780 kg/m³)

M - Used with material weight up to 2,500 lbs/cu yd (1,483 kg/m³)

L - Used with material weight up to 2,000 lbs/cu yd (1,186 kg/m³)

X - Not recommended

SK210LC SPECIFICATIONS

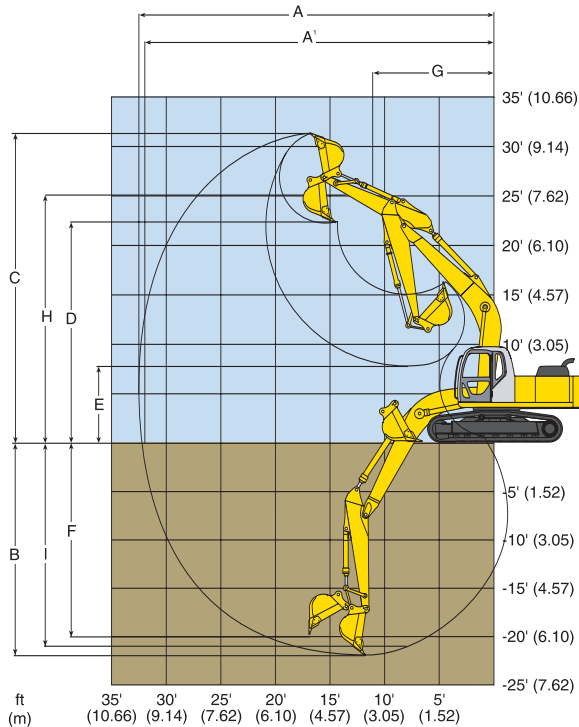

This chart is a graphic representation of the working ranges for the SK210LC equipped with a 9' 8" (2.94 m) arm.

WORKING RANGES Unit ft-in (m)

ATTACHMENTS	Standard Arm 9' 8" (2.94)	Optional Arm 11' 6" (3.5)
A. Max digging reach	32' 6" (9.90)	33' 11" (10.34)
A'. Max digging reach at ground level	31' 11" (9.73)	33' 4" (10.17)
B. Max digging depth	22' 0" (6.70)	23' 10" (7.26)
C. Max digging height	31' 11" (9.73)	32' 0" (9.75)
D. Max dumping clearance	22' 8" (6.91)	22' 10" (6.97)
E. Min dumping clearance	8' 0" (2.43)	6' 2" (1.87)
F. Max vertical wall digging depth	20' 0" (6.1)	21' 3" (6.47)
G. Min front swing radius	11' 7" (3.54)	11' 5" (3.48)
H. Height at min swing radius	25' 2" (7.68)	25' 4" (7.72)
I. Digging depth for 8' (2.4m) flat bottom	21' 5" (6.52)	23' 3" (7.08)

DIGGING FORCE Unit lbf (kN)

		9'8" (2.94 m) Arm	11'6" (3.5 m) Arm
Bucket digging force	ISO	*34,613 (*154)	*34,613 (*154)
Bucket digging force	SAE	*31,700 (*141)	*31,700 (*141)
Arm crowding force	ISO	*24,692 (*110)	*22,267 (*99)
Arm crowding force	SAE	*24,500 (*109)	*22,100 (*98)

*Power Boost engaged

PERFORMANCE

Travel speed	3.7/2.2 mph (6.0/3.6 km/h)
Swing speed	12.5 rpm
Gradeability	35 degrees (70%)
Drawbar pulling force	51,500 lbf (229 kN)

SPECIFICATION SUMMARY

GENERAL

Operating weight with Bucket	lb (kg)	47,800 (21,700)
Bucket Capacity Range	cu yd (m ³)	.63-1.8 (.48-1.4)
Counterweight	lb (kg)	10,230 (4,639)

ENGINE

Make and Model	F4GE9684E-J6	
Displacement	cu in (L)	409 (6.7)
Bore and Stroke	in (mm)	4.09"x5.20" (104x132)
Horsepower SAE NET	HP/RPM (KW/RPM)	150@2,000 (112@2,000)

WORKING RANGES (Std. Arm)

Standard Arm	ft-in (m)	9' 8" (2.94)
Bucket Digging Force	lb (kg)	31,700 (14,379)
Arm Crowding Force	lb (kg)	24,500 (11,113)
Ground Level Reach	ft-in (m)	31' 11" (9.73)
Max. Digging Depth	ft-in (m)	22' 0" (6.70)
Max. Dumping Height	ft-in (m)	22' 8" (6.91)
Max. Vertical Wall Digging Depth	ft-in (m)	20' 0" (6.10)
Max Lift Capacity-Side	lb (kg)	9,090 (4,120)
@ 20' Radius & Ground Level-Front	lb (kg)	14,990 (6,800)

HYDRAULIC SYSTEM

Hydraulic Pump	Tandem Variable Displacement	2VP+1FG
Rated Oil Flow	gpm (L/m)	2x58.1 (2x220)
Operating Pressure	Implement-psi (MPa)	4,980 (34.3)

REFILLING CAPACITIES Unit: US gal (liters)

Fuel tank	97.7 (370)
Hydraulic oil reservoir	38.6 (146)
Hydraulic system including oil reservoir	60.8 (230)
Cooling system	5.8 (26)
Engine oil	5.3 (20)

UNDERCARRIAGE

Track Overall Length	ft-in (m)	14' 7" (4.45)
Track Overall Width w/Std. Shoe	ft-in (m)	10' 6" (3.19)
Track Shoe	in (mm)	31.5" (800)
Travel Speed	mph (km/h)	3.7/2.2 (6.0/3.6)
Draw Bar Pull	lb (kg)	51,500 (299)
Ground Bearing Pressure	psi (Kpa)	4.9 (0.34)
Ground Clearance	in (mm)	17.7" (450)

SWING

Swing Speed	rpm	12.5
Tail Swing Radius	ft-in (m)	9' 0" (2.73)
Swing Torque	lb-ft (kN • m)	52,700 (71.5)

SHIPPING DIMENSIONS

Height	ft-in (m)	9' 11" (3.03)
Width w/Std. Shoe	ft-in (m)	10' 6" (3.19)
Length	ft-in (m)	31' 0" (9.45)

ACERA
Mark 8™

SK210LC LIFT CAPACITIES — 9' 8" Arm

LIFTING CAPACITY DIAGRAM

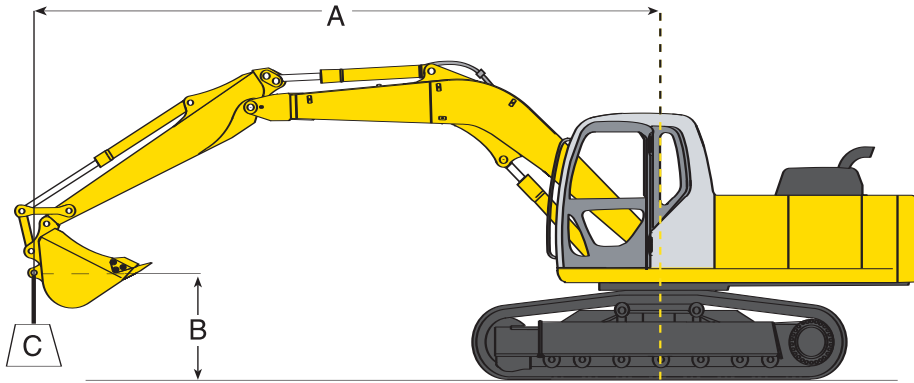

- A Reach swing centerline to bucket hook
- B Bucket hook height above/below ground
- C Lifting capacities in pounds and kilograms
 - Max discharge pressure: 5,480 psi (385 kg/cm²)
 - Track shoe: 31.5" (800 mm) Triple grouser
 - Boom: 18' 6" (5.65 m)

LIFTING CAPACITY — 31.5" (800 mm) triple grouser shoe

Based on machine equipped with — Arm: 9' 8" (2.94 m) Bucket: SAE heaped 1.05 cu. yd. (.080 m³) bucket

B	A	LIFT POINT RADIUS										AT MAX. REACH		
		5' (1.5 m)		10' (3.0 m)		15' (4.6 m)		20' (6.1 m)		25' (7.6 m)		RADIUS		
														RADIUS
25' (7.6 m)	lb kg							*7,990 *3,620	*7,990 *3,620			*7,110 *3,220	*7,110 *3,220	20' 5" (6.23 m)
20' (6.1 m)	lb kg							*11,270 *5,110	11,050 5,010			*6,690 *3,030	*6,690 *3,030	24' 2" (7.37 m)
15' (4.6 m)	lb kg							*12,420 *5,630	10,620 4,810	*10,210 *4,630	7,150 3,240	*6,690 *3,030	6,410 2,900	26' 5" (8.06 m)
10' (3.0 m)	lb kg			*28,490 *12,920	*28,490 *12,920	*18,240 *8,270	15,830 7,180	*14,300 *6,480	9,990 4,530	11,140 5,050	6,870 3,110	*7,020 *3,180	5,710 2,590	27' 8" (8.43 m)
5' (1.5 m)	lb kg			*17,460 *7,910	*17,460 *7,910	*22,200 *10,070	14,480 6,570	15,470 7,010	9,350 4,240	10,790 4,890	6,550 2,970	*7,700 *3,490	5,430 2,460	27' 11" (8.51 m)
Ground Level	lb kg			*19,420 *8,800	*19,420 *8,800	24,060 10,910	13,670 6,200	14,940 6,770	8,880 4,020	10,520 4,770	6,300 2,860	*8,920 *4,040	5,500 2,490	27' 3" (8.30 m)
-5' (-1.5 m)	lb kg	*17,010 *7,710	*17,010 *7,710	*27,300 *12,380	26,470 12,000	23,720 10,750	13,390 6,070	14,680 6,660	8,660 3,920	10,420 4,720	6,210 2,810	10,060 4,560	6,000 2,720	25' 7" (7.80 m)
-10' (-3.0 m)	lb kg	*25,890 *11,740	*25,890 *11,740	*32,510 *14,740	26,890 12,190	*22,610 *10,250	13,490 6,110	14,740 6,680	8,710 3,950			12,140 5,500	7,250 3,280	22' 8" (6.92 m)
-15' (-4.6 m)	lb kg			*24,850 *11,270	*24,850 *11,270	*17,670 *8,010	13,980 6,340					*13,950 *6,320	10,580 4,790	18' 0" (5.50 m)



Rating over front















Rating over side/360 degrees

Notes:

1. Do not attempt to lift or hold any load that exceeds these rated values at their specified load radii and heights. Weight of all accessories must be deducted from the above lifting capacities.
2. Lifting capacities assume a machine standing on a level, firm, and uniform supporting surface. Operator must make allowance for job conditions such as soft or uneven ground, out of level conditions, side loads, sudden stopping of loads, hazardous conditions, inexperienced personnel, weight of various other buckets, lifting slings, attachments, etc.
3. Ratings at bucket lift hook.
4. The above rated loads are in compliance with SAE Hydraulic Excavator Lift Capacity Standard J 1097. They do not exceed 87% of hydraulic lifting capacity or 75% of tipping load. Rated loads marked with an asterisk (*) are limited by hydraulic capacity rather than tipping load.
5. Operator should be fully acquainted with the Operator's and Maintenance Manuals before operating this machine. Rules for safe operation of equipment should be followed at all times.
6. Capacities apply only to the machine as originally manufactured and normally equipped by KOBELCO Construction Machinery America LLC.













LIFTING CAPACITY – 27.6" (700 mm) triple grouser shoe

Based on machine equipped with — Arm: 9' 8" (2.94 m) Bucket: SAE heaped 1.05 cu. yd. (.080 m³) bucket

A B	LIFT POINT RADIUS										AT MAX. REACH			
	5' (1.5 m)		10' (3.0 m)		15' (4.6 m)		20' (6.1 m)		25' (7.6 m)		RADIUS			
														
25' (7.6 m)	lb							*7,990	*7,990			*7,110	*7,110	20' 5"
	kg							*3,620	*3,620			*3,220	*3,220	(6.23 m)
20' (6.1 m)	lb							*11,270	10,920			*6,690	*6,690	24' 2"
	kg							*5,110	4,950			*3,030	*3,030	(7.37 m)
15' (4.6 m)	lb							*12,420	10,490	*10,210	7,060	*6,690	6,320	26' 5"
	kg							*5,630	4,760	*4,630	3,200	*3,030	2,860	(8.06 m)
10' (3.0 m)	lb			*28,490	*28,490	*18,240	15,640	*14,300	9,860	10,990	6,770	*7,020	5,630	27' 8"
	kg			*12,920	*12,920	*8,270	7,090	*6,480	4,470	4,980	3,070	*3,180	2,550	(8.43 m)
5' (1.5 m)	lb			*17,460	*17,460	*22,200	14,300	15,270	9,220	10,640	6,450	*7,700	5,340	27' 11"
	kg			*7,910	*7,910	*10,070	6,480	6,920	4,180	4,820	2,920	*3,490	2,420	(8.51 m)
Ground Level	lb			*19,420	*19,420	23,740	13,490	14,730	8,750	10,370	6,210	*8,920	5,410	27' 3"
	kg			*8,800	*8,800	10,770	6,110	6,680	3,970	4,700	2,810	*4,040	2,450	(8.30 m)
-5' (-1.5 m)	lb	*17,010	*17,010	*27,300	26,130	23,400	13,200	14,480	8,530	10,270	6,110	9,910	5,910	25' 7"
	kg	*7,710	*7,710	*12,380	11,850	10,610	5,990	6,560	3,870	4,650	2,770	4,490	2,680	(7.80 m)
-10' (-3.0 m)	lb	*25,890	*25,890	*32,510	26,550	*22,610	13,300	14,540	8,580			11,970	7,140	22' 8"
	kg	*11,740	*11,740	*14,740	12,040	*10,250	6,030	6,590	3,890			5,420	3,230	(6.92 m)
-15' (-4.6 m)	lb			*24,850	*24,850	*17,670	13,790					*13,950	10,440	18' 0"
	kg			*11,270	*11,270	*8,010	6,250					*6,320	4,730	(5.50 m)

LIFTING CAPACITY – 35.4" (900 mm) triple grouser shoe

Based on machine equipped with — Arm: 9' 8" (2.94 m) Bucket: SAE heaped 1.05 cu. yd. (.080 m³) bucket

A B	LIFT POINT RADIUS										AT MAX. REACH			
	5' (1.5 m)		10' (3.0 m)		15' (4.6 m)		20' (6.1 m)		25' (7.6 m)		RADIUS			
														
25' (7.6 m)	lb							*7,990	*7,990			*7,110	*7,110	20' 5"
	kg							*3,620	*3,620			*3,220	*3,220	(6.23 m)
20' (6.1 m)	lb							*11,270	11,160			*6,690	*6,690	24' 2"
	kg							*5,110	5,060			*3,030	*3,030	(7.37 m)
15' (4.6 m)	lb							*12,420	10,730	*10,210	7,240	*6,690	6,490	26' 5"
	kg							*5,630	4,860	*4,630	3,280	*3,030	2,940	(8.06 m)
10' (3.0 m)	lb			*28,490	*28,490	*18,240	15,990	*14,300	10,100	11,270	6,950	*7,020	5,790	27' 8"
	kg			*12,920	*12,920	*8,270	7,250	*6,480	4,580	5,110	3,150	*3,180	2,620	(8.43 m)
5' (1.5 m)	lb			*17,460	*17,460	*22,200	14,650	15,650	9,460	10,920	6,630	*7,700	5,500	27' 11"
	kg			*7,910	*7,910	*10,070	6,640	7,090	4,290	4,950	3,010	*3,490	2,490	(8.51 m)
Ground Level	lb			*19,420	*19,420	24,340	13,840	15,120	8,990	10,650	6,390	*8,920	5,570	27' 3"
	kg			*8,800	*8,800	11,040	6,270	6,850	4,070	4,830	2,890	*4,040	2,520	(8.30 m)
-5' (-1.5 m)	lb	*17,010	*17,010	*27,300	26,770	24,000	13,550	14,860	8,770	10,550	6,290	10,190	6,080	25' 7"
	kg	*7,710	*7,710	*12,380	12,140	10,880	6,140	6,740	3,970	4,780	2,850	4,620	2,750	(7.80 m)
-10' (-3.0 m)	lb	*25,890	*25,890	*32,510	27,190	*22,610	13,650	14,920	8,820			12,290	7,340	22' 8"
	kg	*11,740	*11,740	*14,740	12,330	*10,250	6,190	6,770	4,000			5,570	3,320	(6.92 m)
-15' (-4.6 m)	lb			*24,850	*24,850	*17,670	14,140					*13,950	10,710	18' 0"
	kg			*11,270	*11,270	*8,010	6,410					*6,320	4,850	(5.50 m)

SK210LC LIFT CAPACITIES — 11' 6" Arm



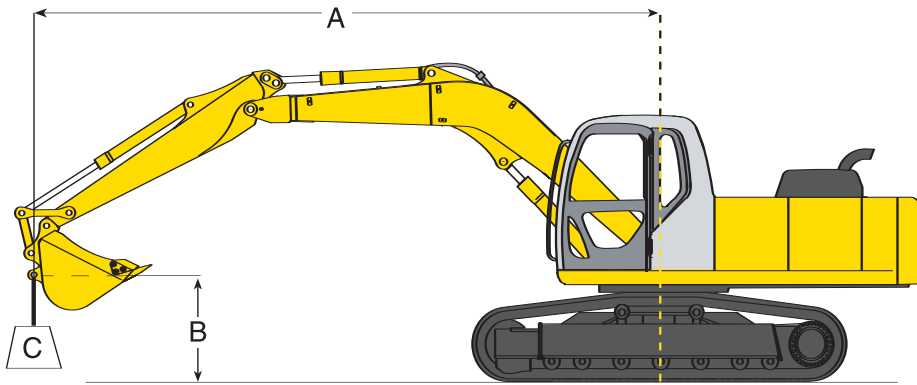









LIFTING CAPACITY DIAGRAM



- A Reach swing centerline to bucket hook
- B Bucket hook height above/below ground
- C Lifting capacities in pounds and kilograms
 - Max discharge pressure: 5,480 psi (385 kg/cm²)
 - Track shoe: 31.5" (800 mm) Triple grouser
 - Boom: 18' 6" (5.65 m)

LIFTING CAPACITY — 31.5" (800 mm) triple grouser shoe

Based on machine equipped with — Arm: 11' 6" (2.94 m) Bucket: SAE heaped 0.92 cu. yd. (.070 m³) bucket

B	A	LIFT POINT RADIUS										AT MAX. REACH				
		5' (1.5 m)		10' (3.0 m)		15' (4.6 m)		20' (6.1 m)		25' (7.6 m)		RADIUS				
																
25' (7.6 m)	lb													*6,190	*6,190	22' 3"
	kg													*2,800	*2,800	(6.79 m)
20' (6.1 m)	lb									*7,170	*7,170	*5,880	*5,880	*5,880	*5,880	25' 9"
	kg									*3,250	*3,250	*2,660	*2,660	*2,660	*2,660	(7.85 m)
15' (4.6 m)	lb							*11,150	10,760	*10,210	7,210	*5,910	5,800	*5,910	5,800	27' 11"
	kg							*5,050	4,880	*4,630	3,270	*2,680	2,630	*2,680	2,630	(8.51 m)
10' (3.0 m)	lb					*16,300	16,190	*13,130	10,090	11,160	6,870	*6,210	5,180	*6,210	5,180	29' 0"
	kg					*7,390	7,340	*5,950	4,570	5,060	3,110	*2,810	2,340	*2,810	2,340	(8.85 m)
5' (1.5 m)	lb			*27,200	*27,200	*20,660	14,690	*15,300	9,380	10,760	6,510	*6,820	4,910	*6,820	4,910	29' 3"
	kg			*12,330	*12,330	*9,370	6,660	*6,940	4,250	4,880	2,950	*3,090	2,220	*3,090	2,220	(8.93 m)
Ground Level	lb	*9,040	*9,040	*21,740	*21,740	*23,590	13,670	14,890	8,820	10,420	6,200	*7,870	4,940	*7,870	4,940	28' 7"
	kg	*4,100	*4,100	*9,850	*9,850	*10,690	6,200	6,750	4,000	4,720	2,810	*3,560	2,240	*3,560	2,240	(8.73 m)
-5' (-1.5 m)	lb	*15,800	*15,800	*26,620	26,060	23,540	13,210	14,530	8,500	10,230	6,030	9,050	5,320	9,050	5,320	27' 1"
	kg	*7,160	*7,160	*12,070	11,820	10,670	5,990	6,590	3,850	4,640	2,730	4,100	2,410	4,100	2,410	(8.25 m)
-10' (-3.0 m)	lb	*23,100	*23,100	*34,600	26,300	*23,360	13,170	14,470	8,440			10,650	6,280	10,650	6,280	24' 4"
	kg	*10,470	*10,470	*15,690	11,930	*10,590	5,970	6,560	3,830			4,830	2,840	4,830	2,840	(7.43 m)
-15' (-4.6 m)	lb	*32,050	*32,050	*28,340	*27,030	*19,720	13,510	*13,880	8,720			*13,730	8,640	*13,730	8,640	20' 1"
	kg	*14,530	*14,530	*12,850	*12,260	*8,940	6,120	*6,290	3,950			*6,220	3,910	*6,220	3,910	(6.13 m)
-20' (-6.1 m)	lb											*13,280	*13,280	*13,280	*13,280	12' 9"
	kg											*6,020	*6,020	*6,020	*6,020	(3.88 m)



Rating over front















Rating over side/360 degrees

Notes:

1. Do not attempt to lift or hold any load that exceeds these rated values at their specified load radii and heights. Weight of all accessories must be deducted from the above lifting capacities.
2. Lifting capacities assume a machine standing on a level, firm, and uniform supporting surface. Operator must make allowance for job conditions such as soft or uneven ground, out of level conditions, side loads, sudden stopping of loads, hazardous conditions, inexperienced personnel, weight of various other buckets, lifting slings, attachments, etc.
3. Ratings at bucket lift hook.
4. The above rated loads are in compliance with SAE Hydraulic Excavator Lift Capacity Standard J 1097. They do not exceed 87% of hydraulic lifting capacity or 75% of tipping load. Rated loads marked with an asterisk (*) are limited by hydraulic capacity rather than tipping load.
5. Operator should be fully acquainted with the Operator's and Maintenance Manuals before operating this machine. Rules for safe operation of equipment should be followed at all times.
6. Capacities apply only to the machine as originally manufactured and normally equipped by KOBELCO Construction Machinery America LLC.













LIFTING CAPACITY – 27.6" (700 mm) triple grouser shoe

Based on machine equipped with — Arm: 11' 6" (2.94 m) Bucket: SAE heaped 0.92 cu. yd. (.070 m³) bucket

A		LIFT POINT RADIUS										AT MAX. REACH		
		5' (1.5 m)		10' (3.0 m)		15' (4.6 m)		20' (6.1 m)		25' (7.6 m)				
B	C													RADIUS
		25' (7.6 m)	lb											
	kg													*2,800
20' (6.1 m)	lb													*7,170
	kg													*3,250
15' (4.6 m)	lb													*11,150
	kg													*5,050
10' (3.0 m)	lb													10,640
	kg													4,820
5' (1.5 m)	lb													*10,210
	kg													*4,630
Ground Level	lb													7,110
	kg													3,220
-5' (-1.5 m)	lb													*5,910
	kg													*2,680
-10' (-3.0 m)	lb													*6,210
	kg													*2,810
-15' (-4.6 m)	lb													5,100
	kg													2,310
-20' (-6.1 m)	lb													*6,820
	kg													*3,090
Ground Level	lb													*6,820
	kg													*3,090
-5' (-1.5 m)	lb													*9,040
	kg													*4,100
-10' (-3.0 m)	lb													*15,800
	kg													*7,160
-15' (-4.6 m)	lb													*23,100
	kg													*10,470
-20' (-6.1 m)	lb													*32,050
	kg													*14,530

LIFTING CAPACITY – 35.4" (900 mm) triple grouser shoe

Based on machine equipped with — Arm: 11' 6" (2.94 m) Bucket: SAE heaped 0.92 cu. yd. (.070 m³) bucket

A		LIFT POINT RADIUS										AT MAX. REACH		
		5' (1.5 m)		10' (3.0 m)		15' (4.6 m)		20' (6.1 m)		25' (7.6 m)				
B	C													RADIUS
		25' (7.6 m)	lb											
	kg													*2,800
20' (6.1 m)	lb													*7,170
	kg													*3,250
15' (4.6 m)	lb													*11,150
	kg													*5,050
10' (3.0 m)	lb													10,880
	kg													4,930
5' (1.5 m)	lb													*10,210
	kg													*4,630
Ground Level	lb													7,290
	kg													3,300
-5' (-1.5 m)	lb													*5,910
	kg													*2,680
-10' (-3.0 m)	lb													*6,210
	kg													*2,810
-15' (-4.6 m)	lb													5,250
	kg													2,380
-20' (-6.1 m)	lb													*16,300
	kg													*7,390
Ground Level	lb													*13,130
	kg													*5,950
-5' (-1.5 m)	lb													10,200
	kg													4,620
-10' (-3.0 m)	lb													11,300
	kg													5,120
-15' (-4.6 m)	lb													6,960
	kg													3,150
-20' (-6.1 m)	lb													*6,210
	kg													*2,810
Ground Level	lb													*6,210
	kg													*2,810
-5' (-1.5 m)	lb													14,860
	kg													6,740
-10' (-3.0 m)	lb													*15,300
	kg													*6,940
-15' (-4.6 m)	lb													9,490
	kg													4,300
-20' (-6.1 m)	lb													10,890
	kg													4,940
Ground Level	lb													6,590
	kg													2,990
-5' (-1.5 m)	lb													*6,820
	kg													*3,090
-10' (-3.0 m)	lb													*9,040
	kg													*4,100
-15' (-4.6 m)	lb													*15,800
	kg													*7,160
-20' (-6.1 m)	lb													*23,100
	kg													*10,470

ACERA Mark 8™



STANDARD EQUIPMENT

- AM/FM radio
- Arm: 9' 8" (2.94 m) with vertical ribbed rock guard, tapped blocks, ready for auxiliary attachments
- Audible warning system for high coolant temperature, low engine oil pressure, clogged air filter and oil replacement interval
- Auxiliary valve with flow control
- Boom, 18' 6" (5.65 m)
- Boom and arm holding (anti-drift) valves
- Cab is die formed, modular steel full-vision, sound insulated, with viscous silicon-filled mounts, windshield wiper, heater and defroster, cigarette lighter, ashtray, floor mat, cab light, control lever lock, tinted skylight with damper cylinder
- Climate control air conditioning/heating system
- Counter weight 10,230 lbs. (4,639 kg)
- Display monitor mounted on multi-function console provides status of following: aging of engine oil, fuel and hydraulic filters, system status, engine preheat, low engine oil pressure, engine coolant temperature, air cleaner restriction, battery charging, fuel level, CPU error and tachometer. Beneath monitor are switches for auto-decel, windshield washer and wiper, mode selector, one/two pump auxiliary hydraulics and swing flashers
- Dual element air cleaner
- Electric horn
- Engine shuts down automatically for low oil pressure
- Heavy duty batteries (2 x12 volt 136 AH)
- Heavy Lift and Power Boost *"without time limit"*
- Hydraulic track adjusters
- Independent travel
- Lifetime lubricated track rollers, idlers and sprockets
- Engine model F4GE9684E-J6
- Mode selection:
 - H Mode — Heavy-duty excavation work
 - S Mode — Standard digging and loading work
 - B Mode — Breaker work
 - A Mode — Demolition work with crusher/nibbler-breaker
- Power outlet, 24 volt to 12 volt converter
- Proportional auto accel system
- Removable clean out screen for radiator
- Removable travel levers with toe tabs
- Self-lubricating bushings in boom foot and boom hoist cylinders
- Service diagnostics:
Computer system displays 68 service items 60 event fault code memory, accessible from cab

- Starting motor (24 v/5.0 KW) 35 amp alternator
- Straight travel system
- Suspension seat — 7-way adjustable with safety belt
- Swing and travel automatic parking brakes
- Swing flashers recessed into counterweight. Off/on switch located on multi-function console in cab
- Swing priority (trenching system) functions automatically
- Swing shockless valve
- Track shoes: 31.5" (800 mm) semi-triple grouser shoes
- Travel—two speed with automatic shift
- Two lever control for boom, arm, bucket and swing; pilot operated wrist controls and foot pedals
- Warm up function of engine and hydraulic system functions automatically
- Work lights —three front and two rear

OPTIONAL EQUIPMENT

- Arm: 11' 6" (3.5 m) with rock guard
- Belly pan guard
- Boom and arm load (lock) valves
- Combined one-way or two-way auxiliary hydraulic piping (one or two pump) with hand or foot controls.
- Control pattern changer (ISO/BHL)
- Front rain visor
- High & wide lower
- Independent pump auxiliary rotation hydraulic system
- Large selection of buckets
- Long reach (50") with heavier counterweight
- Track shoe: 27.6" (700 mm) double bar
- Track shoe: 35.4" (900 mm) triple bar grouser
- Vandalism guards

SEE THE EXCAVATOR EXPERT. YOUR KOBELCO DEALER.

Kobelco makes excavators for every job, large and small, offering a full line of zero-tail-swing compact, short-radius and mid-size excavators, as well as Blade Runner™ excavator-dozers and full-size conventional Acera hydraulic excavators. Every Kobelco excavator is supported by a network of experienced dealers and field service representatives committed to the trouble-free performance of your excavators and the maximum productivity of your business. Kobelco's large parts inventory is readily available to keep your equipment running at peak efficiency. Product and dealer support extends even further – to the engineers and experts located at the Kobelco factory in Calhoun, Georgia and the Kobelco support center in Carol Stream, Illinois who stand behind every Kobelco excavator. Your Kobelco dealer also helps to make equipment affordable with low-rate financing options, lease programs and insurance plans tailored to match your needs.



STRICTLY EXCAVATORS – STRICTLY THE BEST.

KOBELCO®

Kobelco Construction Machinery America LLC
245 E. North Avenue
Carol Stream, IL 60188-2021
866-726-3396 Toll Free
630-260-4000
630-260-4304 Fax

www.kobelcoamerica.com

Products represented in this brochure may include optional equipment.

Note: Due to our policy of continual product improvement, all design, materials and/or specifications are subject to change without advance notice and without liability therefor. Specifications are applicable to units sold in Canada, the United States, its territories and possessions, and may vary outside these areas.

Safety begins with a thorough understanding of the equipment. Always make sure you and your operators read the Operator's Manual before using the equipment. Pay close attention to all safety and operating decals and never operate machinery without all shields, protective devices and structures in place.